

Mounting the Damper Roller Unit (B)

To use the high-volume roll paper supply (RHU-T500) in the horizontal or vertical mount, use the following procedure to remove the damper roller unit (A), which is mounted to the TUP500 printer unit. Replace it with the supplied damper roller unit (B).

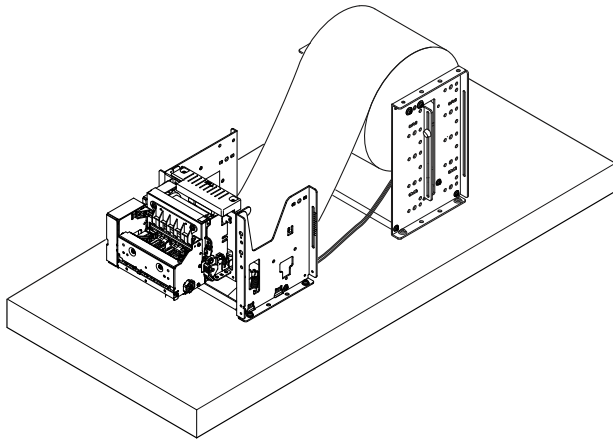

TUP500 Horizontal Mount

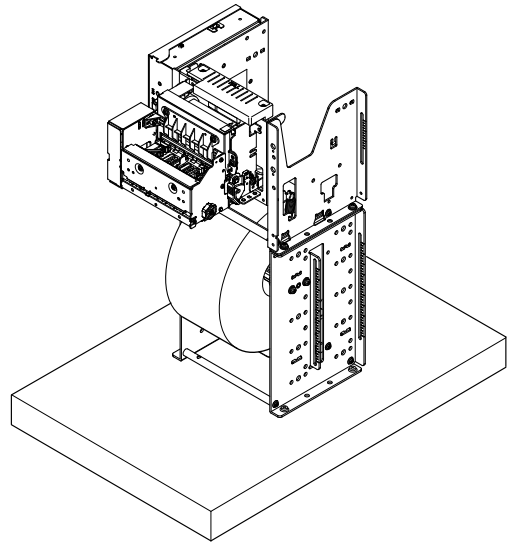

TUP500 Vertical Mount

For horizontal mount

1. Remove the two screws to remove the damper roller unit (A).

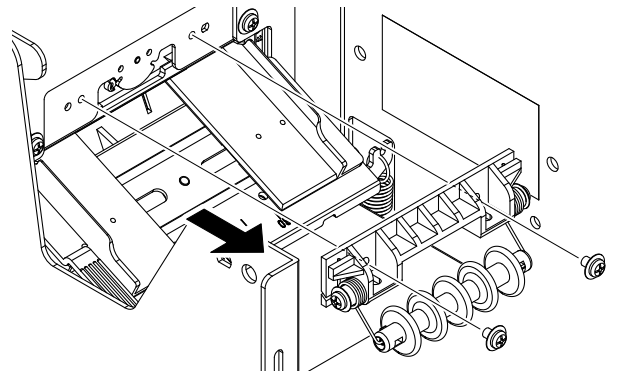

2. Use the screws that you removed in step 1 to remount the accessory damper roller unit (B).

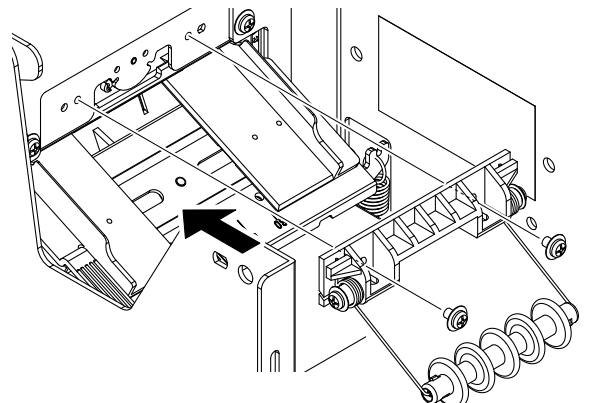

For vertical mount

1. Remove the damper roller unit (A), using the same procedure as the horizontal layout.
2. Remove the two plastic thumb screws, and remove the board chassis (U) unit.
3. Remove the four screws from the back.
4. Disconnect the cable from the six connectors on the main board. Then, remove the board chassis (L) unit.

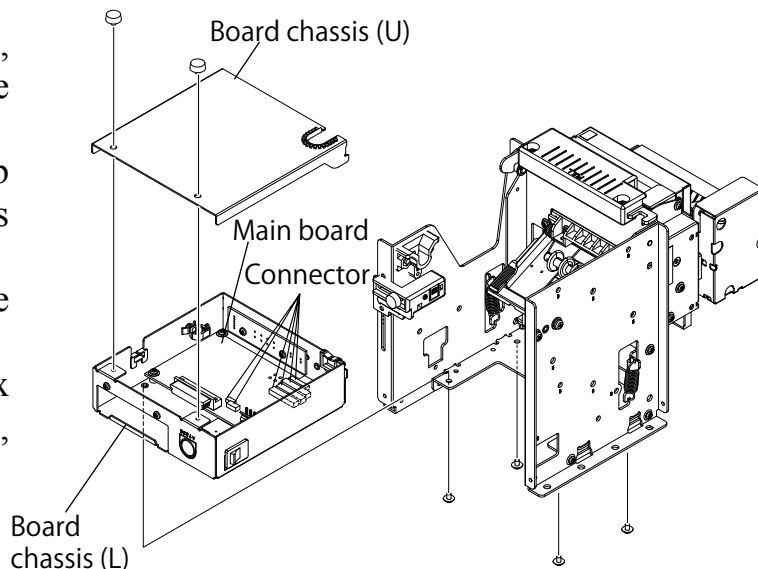

5. Using the two screws that are supplied, mount the damper base to the mechanical base position indicated on the right.

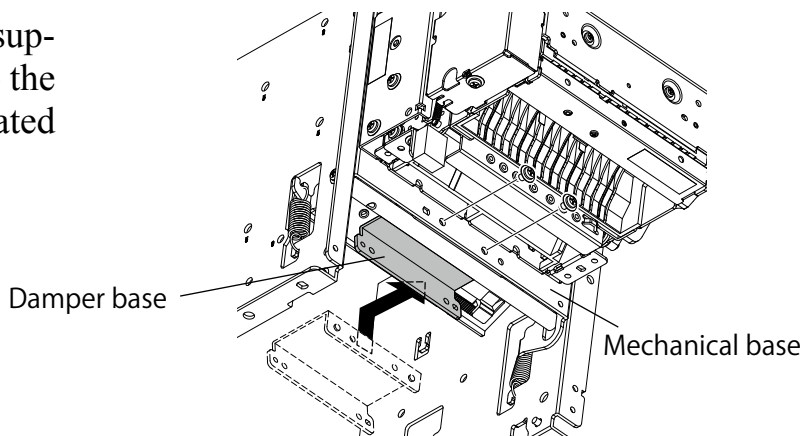

6. Using the two screws that are supplied, mount the damper roller unit (B) to the damper base that you have mounted.

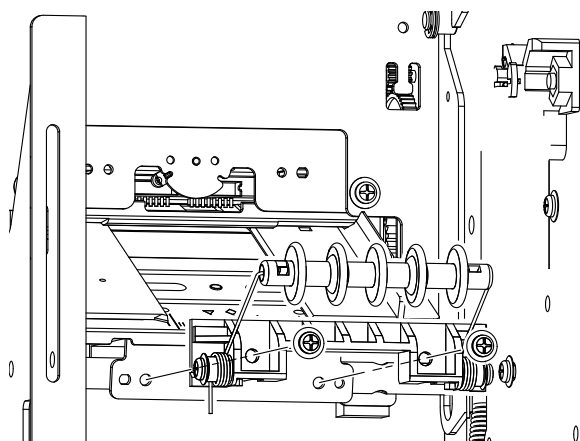

For details on the RHU-500 installation, see sections 7 and 8 of the TUP500 Series Product Specifications.